

Schall-Ex® L-8/30 WS

DETAILS

| | |
|---------------|--|
| Articlenumber | 1-1000 |
| Function | hinged door |
| Türenmaterial | timber |
| Application | interior door |
| Usage | sound protection, smoke protection, fire protection, accessibility |

TECHNICAL DATA

| | |
|------------------------|------------------------------|
| Width | 8 mm |
| Height | 30 mm |
| Min. delivery length | 235 mm |
| Max. delivery length | 2000 mm |
| Standard length | 708, 833, 958, 1083, 1208 mm |
| max. travel | 20 mm |
| Actuation | single-sided |
| Actuator | sliding acuator |
| removableInner profile | yes |
| Outerprofile | aluminium |
| Surface | plate finish |
| Sealingprofile | silicone, self-extinguishing |

FITTING

| | |
|--------|----------------------|
| Fixing | WS - fixing brackets |
|--------|----------------------|

EXAMINATIONS AND CERTIFICATES

| | |
|-----------------------|-----|
| Sound | yes |
| Permanent function IM | yes |
| Mio Certificate | yes |
| Barrier free | yes |
| UL | yes |
| EPD | yes |
| Certifire | yes |

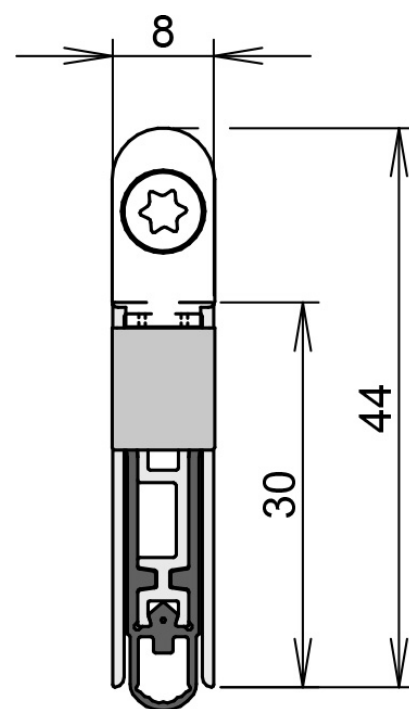
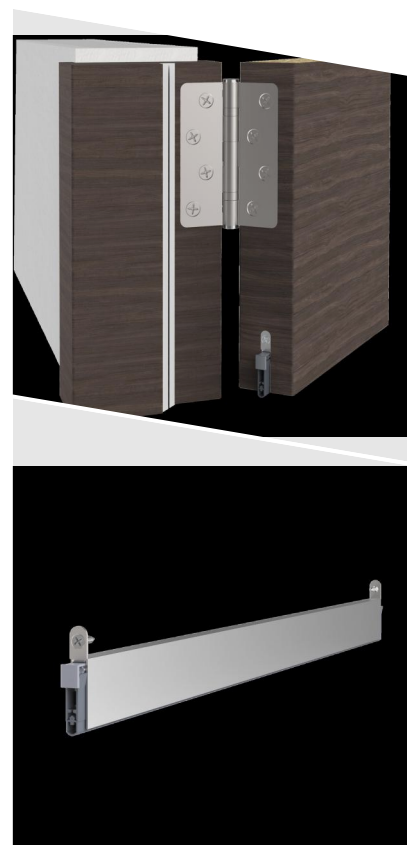



I-Ex[®] L-8/30 WS

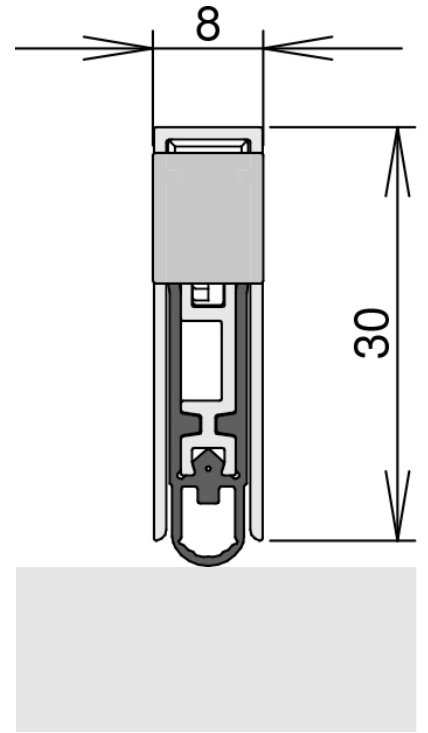

Schall-Ex[®] 30 WS



Schall-Ex® L-8/30 WS

